

mcosmos CAT-1000

Bulletin No. 2076

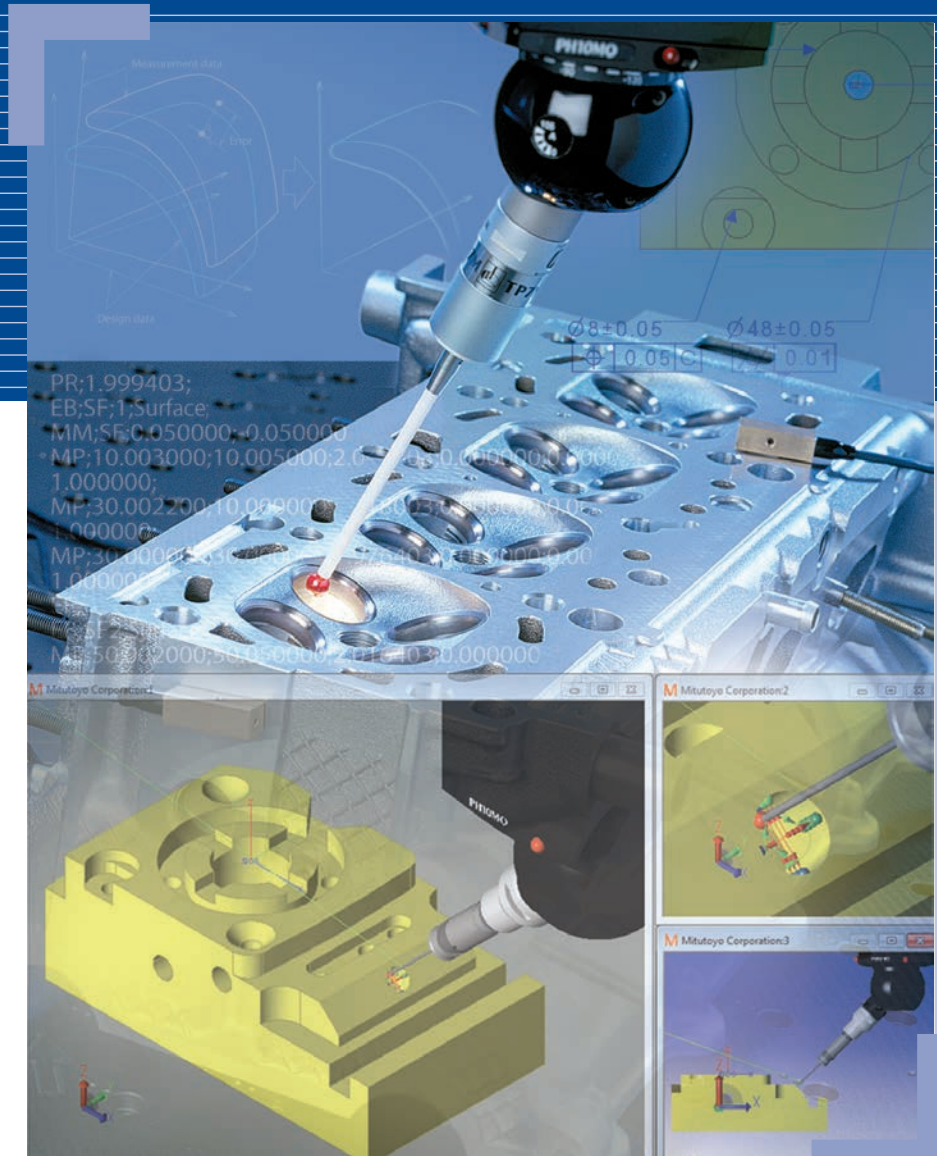

Computer Assisted Technology CAT-1000 Model Based Definition

CMM System Manager

From the Part Manager the CMM System Manager allows rack positions and probe configurations to be predefined for multiple machines or I++ DME Interface (Dimensional Measuring Equipment).

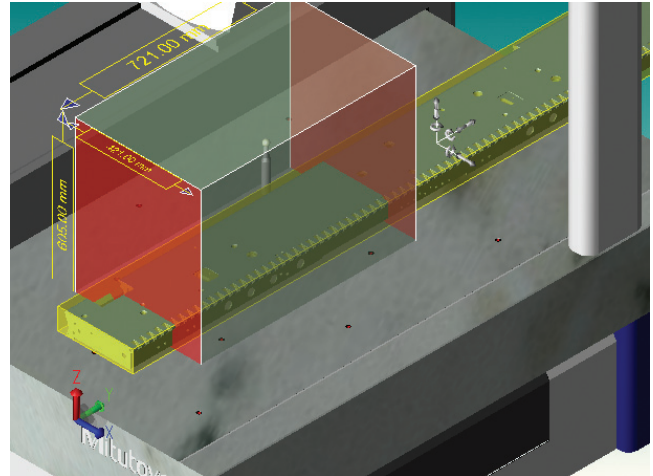
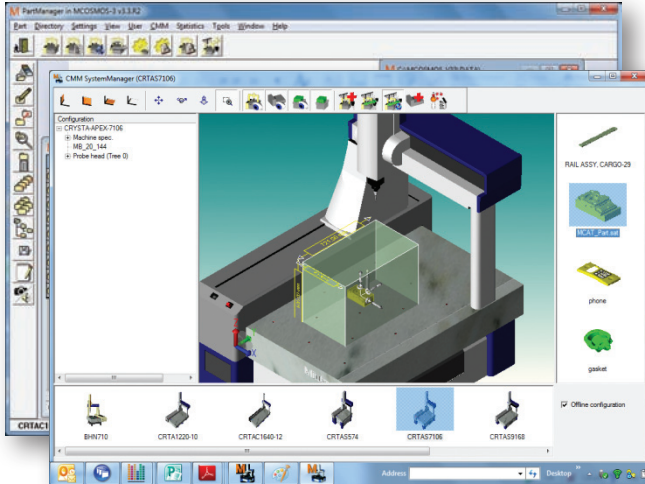

The CMM System Manager allows you create a virtual representation of your CMM for simulation. New Mitutoyo models or legacy models such as FN series and BHN series machines can be selecting based on machine stroke. If you have multiple machines they can also be added for simulation or part placement purposes. CAD models can be placed and compared to the true working volume of the machine and indexing probe swivel access.

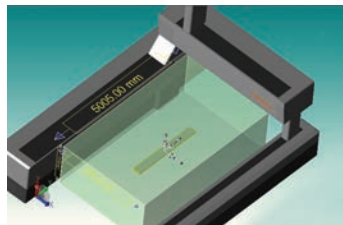
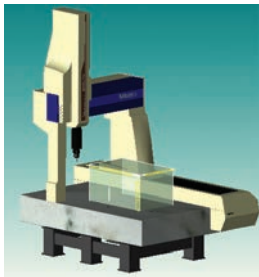

CAT-1000P (Prismatic)

CAT-1000P

Not available for manual CMMs

CAT1000P significantly facilitates the programming of measurement tasks during the GEOPAK learn mode. All data for measuring parts and tolerance evaluations are taken accurately from the CAD model via pointing device (mouse, trackball, etc.) selection. The same principles apply for programming probe paths (clearance and measurement), while at the same time, using the nominal directly off the CAD model for tolerance comparison.

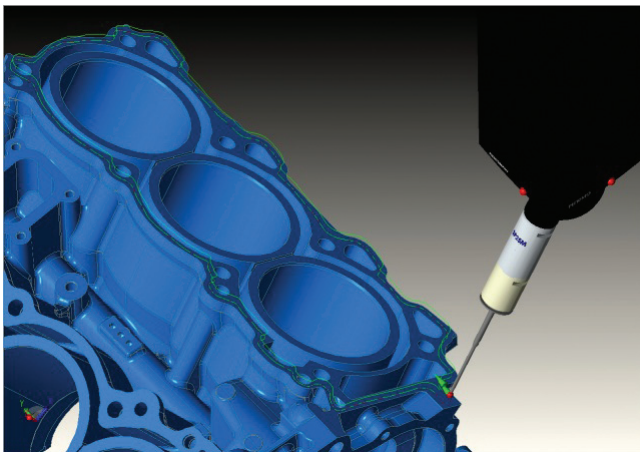

Product Manufacturing Information

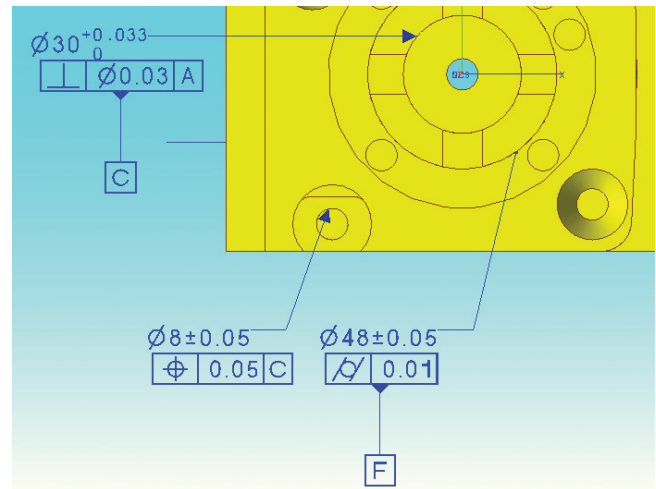

CAT-1000 uses 3D ACIS® Modeler which is Spatial's prominent modeling component used in over 350 customer applications with more than 2 million seats worldwide.

CAT-1000 fully supports and reads PMI (Product Manufacturing Information) which is imbedded in the model for Datum alignment, GD&T Geometric Dimensioning and Tolerancing.

Spatial's 3D InterOp delivers the highest quality data exchange between CAD formats, enabling superior CAD file translation.

The comprehensive suite of translators provides import/export for all applications, including ACIS, CGM and Parasolid-based applications. 3D InterOp is embedded in many of today's leading design, engineering, and manufacturing applications.

CATIA V5, SolidWorks, NX Siemens (Unigraphics), Parasolids, AutoDesk Inventor, Pro-Engineer and IGES or VDAFS exchange formats are available as an option.

Standard with CAT-1000 is ACIS (*.sat) and STEP AP203 which are both licensed copies from Spatial InterOp.

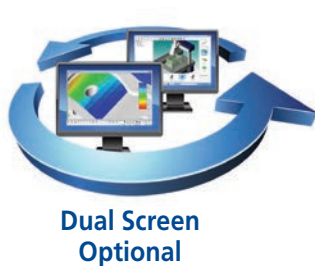

**Virtual Offline
Optional**

MiCAT

Mitutoyo Intelligent Computer Aided Technology

the standard in world
metrology software

cmm

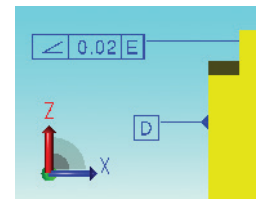

CAT-1000P Geometry

Available in offline and online

CAT-1000P provides the operator visibility of the CMM, probe/changer system, master-ball, and part/fixture locations. It provides a realistic simulation of your environment or DME. Collision detection takes into account all of the possible obstructions and uses a movement box to generate GOTO locations just as you would by using a joystick in GEOPAK.

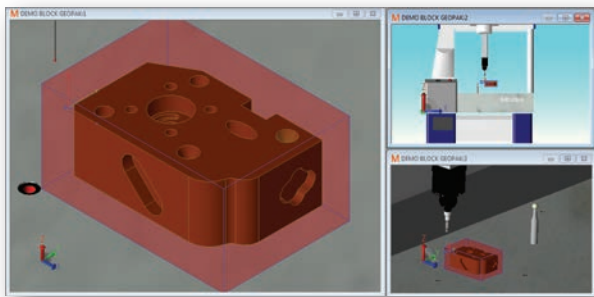

CAT-1000P Multi-Circle Function

To speed up the programming process in GEOPAK CNC, CAT-1000P has created tools to shorten the time by using the nominal CAD data. The Multi circle function allows the operator to drag a window to capture multiple holes in one command. The user may set conditions e.g. a range of diameters so your window will ignore circles that do not meet the condition. e.g. diameter range of 5mm to 10mm will filter out circles outside of this range.

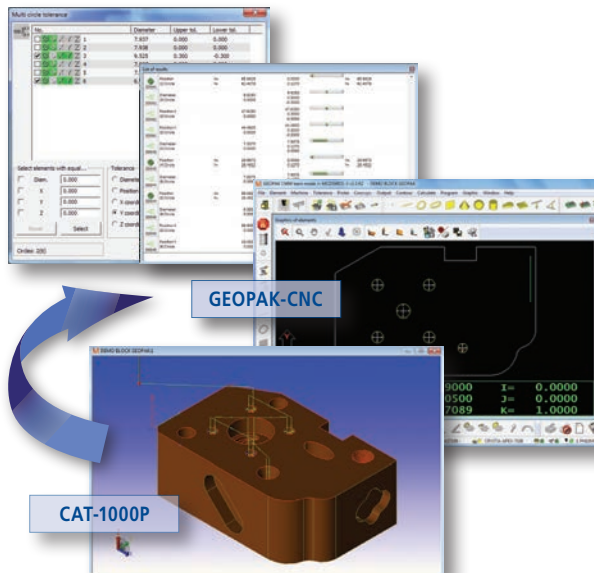

The nominal values are captured directly from the CAD model and tolerance values can be applied to various groups of size and location in the position GEOPAK-CNC part program.

CAT-1000P Collision Avoidance

CAT1000P online or offline eliminates the chance of collision because machine simulates the machine path in advance so the operator has visually accepted before the command is sent to GEOPAK-CNC. This teach mode approach allows operators to confidently to program offline step by step assuring the program will run successful the first time.

CAT-1000P can improve efficiency by reducing spindle down time as a first piece verification is required before production. First piece programs can be created in advance allowing the operator to simply repeat the program in GEOPAK-CNC and give results to production quickly to increase spindle time.

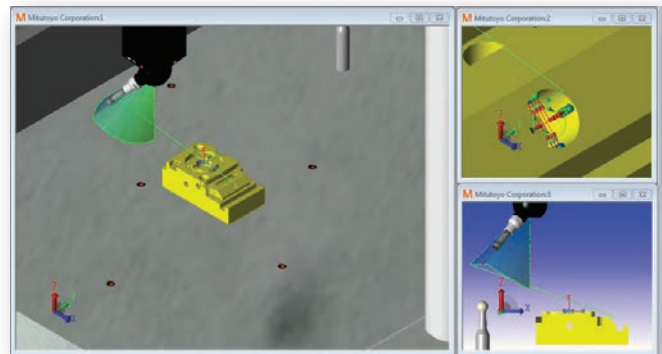

CAT-1000P Auto-Probe Generation

Automatic Probe Generation allows new probe positions to be added as you program the part. It generates the optimal probe stylus orientation for maximum clearance or EWL (effective working length).

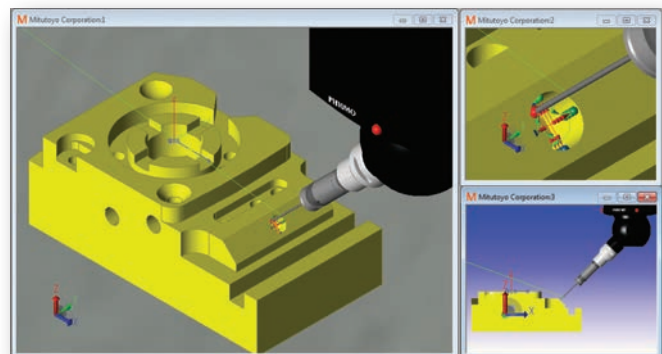

CAT1000P eliminates the time consuming task of data input from paper prints allowing your CMM to work in a paperless environment or by MBD (Model Based Definition).

The same principles apply for programming probe paths (clearance and measurement), Probe paths are displayed graphically in a 3D view and may be changed as needed.

CAT-1000S (Surface Analysis)

CAT-1000S (free-form sculpted)

Available for both GEOPAK CNC and Manual CMMs

CAT-1000S is a highly versatile tool that can be used on a Manual CMM or a CNC CMM. A coordinate system in GEOPAK is compared to the CAD model.

Real-time surface disposition is displayed by showing a color class to determine if there is material to remove or replace.

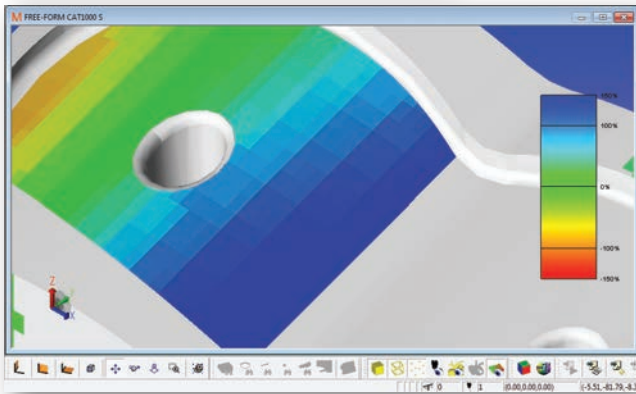
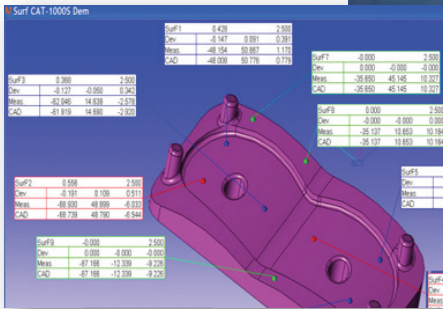

Surface deviation can be displayed as spherical points or as a gradient surface. Cones can also be used to show what direction of the deviation.

CAT-1000S Defined Grid

GEOPAK-CNC only

GEOPAK CNC can create grid pattern to verify the surface points. With a simple one click tool calculates a collision free probe path to measure a grid of surface points that are offset from the edge.

If the CAD model has specific points GEOPAK-CNC can drive the machine normal to the defined points or vertices.

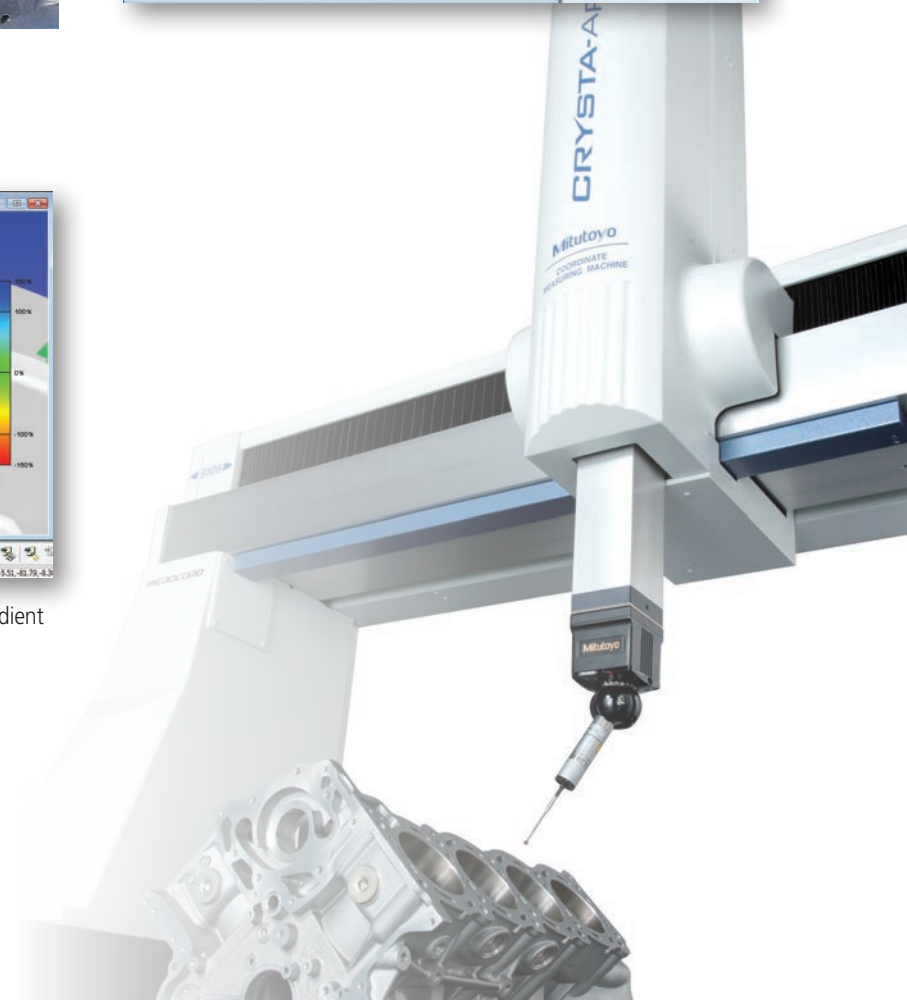
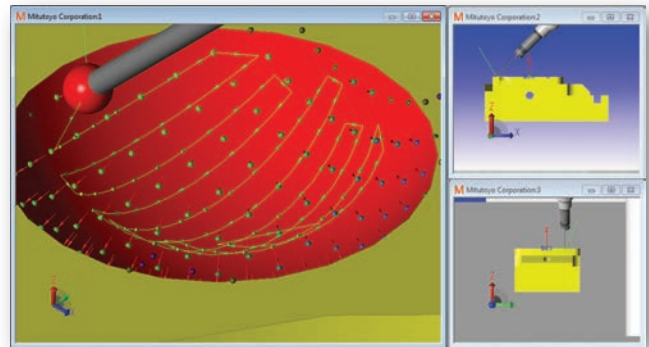

Coordinate Measuring Machines

Vision Measuring Systems

Form Measurement

Optical Measuring

Sensor Systems

Testing Equipment and
Seismometer

Digital Scale and DRO Systems

Small Tool Instruments and
Data Management

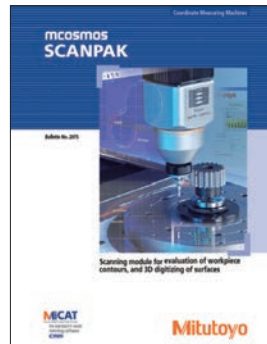
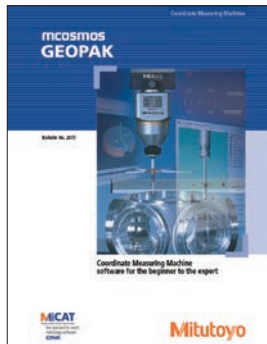

Note: All information regarding our products, and in particular the illustrations, drawings, dimensional and performance data contained in this printed matter as well as other technical data are to be regarded as approximate average values. We therefore reserve the right to make changes to the corresponding designs. The stated standards, similar technical regulations, descriptions and illustrations of the products were valid at the time of printing. In addition, the latest applicable version of our General Trading Conditions will apply. Only quotations submitted by ourselves may be regarded as definitive. Specifications are subject to change without notice.

Mitutoyo products are subject to US Export Administration Regulations (EAR). Re-export or relocation of our products may require prior approval by an appropriate governing authority.

Trademarks and Registrations

Designations used by companies to distinguish their products are often claimed as trademarks. In all instances where Mitutoyo America Corporation is aware of a claim, the product names appear in initial capital or all capital letters. The appropriate companies should be contacted for more complete trademark and registration information.

Mitutoyo America Corporation
www.mitutoyo.com

One Number to Serve You Better
1-888-MITUTOYO (1-888-648-8869)

M³ Solution Centers

Aurora, Illinois
(Corporate Headquarters)

Westford, Massachusetts

Huntersville, North Carolina

Mason, Ohio

Plymouth, Michigan

City of Industry, California

Birmingham, Alabama

Mitutoyo
Precision is our Profession