

# Mitutoyo

Mitutoyo Quality

## MICROCORD LEGEX Series

Ultra-high Accuracy CNC Coordinate Measuring Machine

COORDINATE  
MEASURING MACHINES

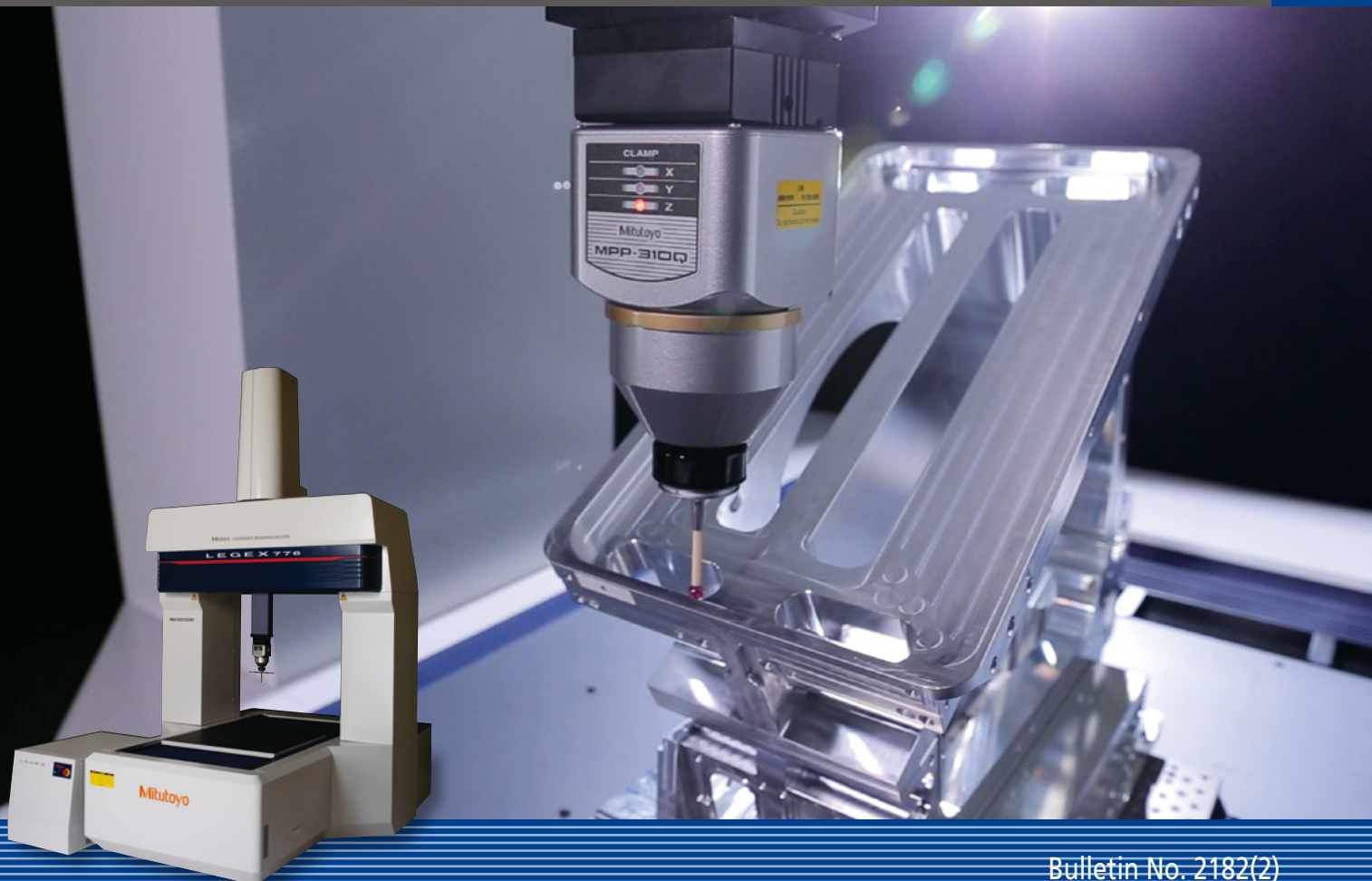

Bulletin No. 2182(2)

The culmination of 80 years of Mitutoyo technology.  
Recognized as the world's ultimate high-accuracy  
measurement technology.

Mitutoyo COORDINATE MEASURING MACHINE

LEGEX 9106

MICROCORD







LEGEX 574

World's leading measurement accuracy of  $E_0.MPE=0.28+L/1000$  is achieved.\*

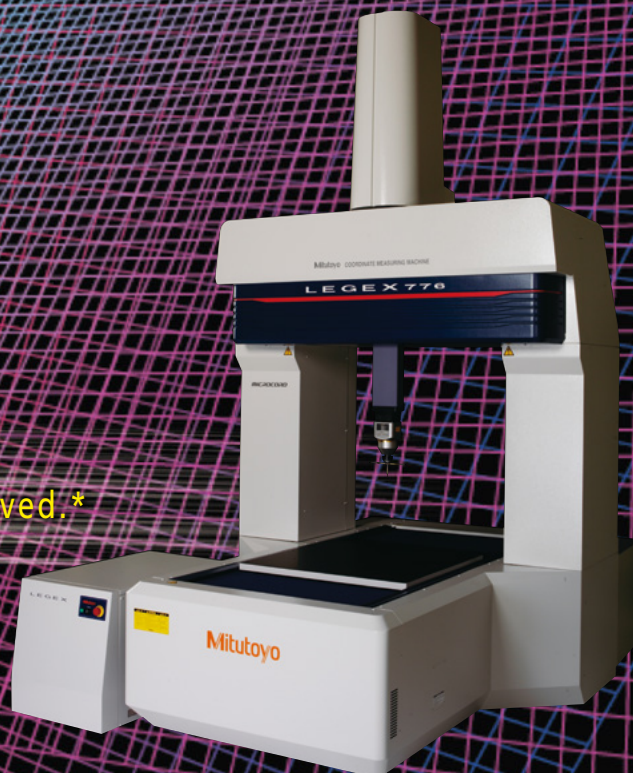

LEGEX 776



LEGEX 9106

\* World's leading measurement accuracy specification as established by Mitutoyo in October 2014.



# Evolving technology

## Thorough analysis and elimination of error factors Part 1

### BASE DESIGN

#### High rigidity

The base of the LEGEX is made from special spheroidal graphite ductile cast iron to a sealed-structure design that provides high rigidity and vibration attenuating characteristics. Mitutoyo engineers used FEM analysis during the design phase to optimize the final configuration and ensure outstanding geometric accuracy by minimizing deformations caused by normal machine operation.

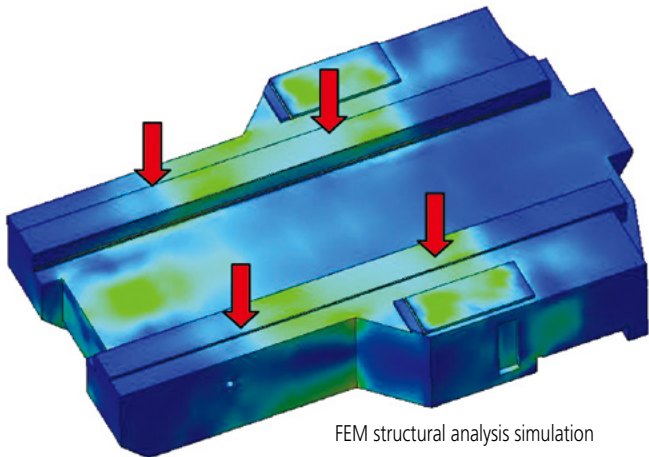

FEM structural analysis simulation

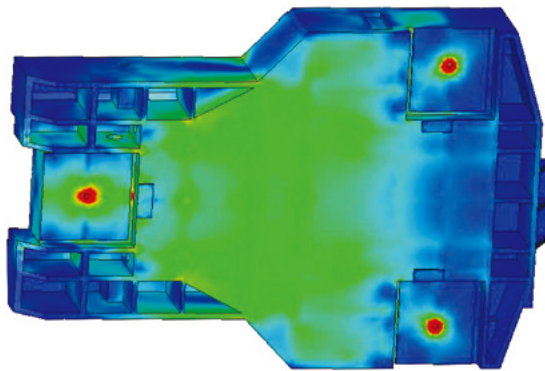

EVOLUTIONAL  
TECHNOLOGIES

#### \*Spheroidal graphite ductile cast iron\*

Cast iron is an alloy of iron, carbon, silicon, manganese, phosphorus, sulfur, and traces of other elements, and exhibits characteristic properties due to the carbon being distributed throughout the metal in the form of graphite.

Ductile cast iron is created by spheroidizing the graphite by adding magnesium alloy to the melt. Compared with normal cast iron, it has great tensile strength, is relatively tough, and has excellent machinability and wear resistance. Ductile cast iron is thus used for components such as automotive parts.

LEGEX employs FCD600 ductile cast iron but made in such a way as to eliminate blow holes and pin holes (defects) of 0.1mm or larger.

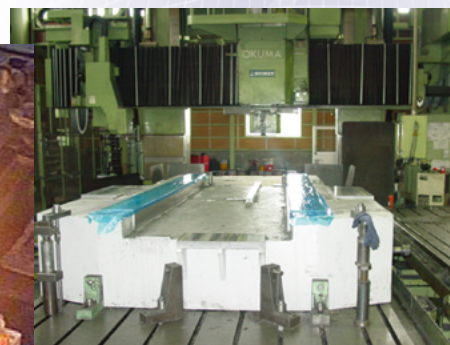

### Integrated Y-axis guide rail

To further increase rigidity and thermal stability, the Y-axis guide rail is integrated with the main unit base.

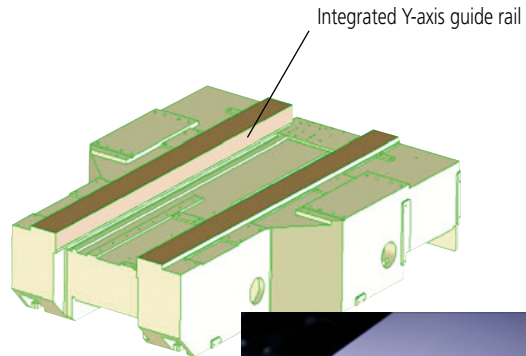

### Ceramic plasma spraying for each axis sliding section

Ceramic plasma spraying is applied to sliding sections for the Y-axis guide rail, X-axis beam, and Z-axis spindle, creating surfaces suitable for highly accurate air-bearing operation. It also produces excellent corrosion resistance.

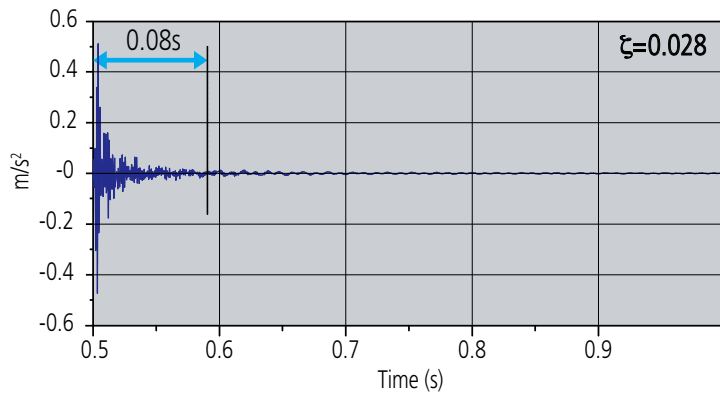
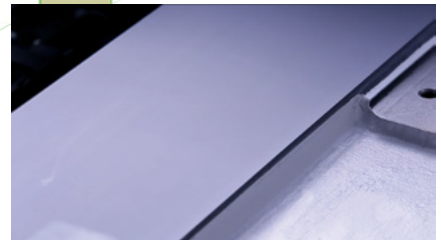

### Vibration attenuation

The LEGEX structure quickly attenuates traverse-induced vibrations and so reduces any adverse effect on measurements. This characteristic also allows ultra-high scanning accuracy to be realized.

## WORKTABLES

Ceramic Coated is standard US product

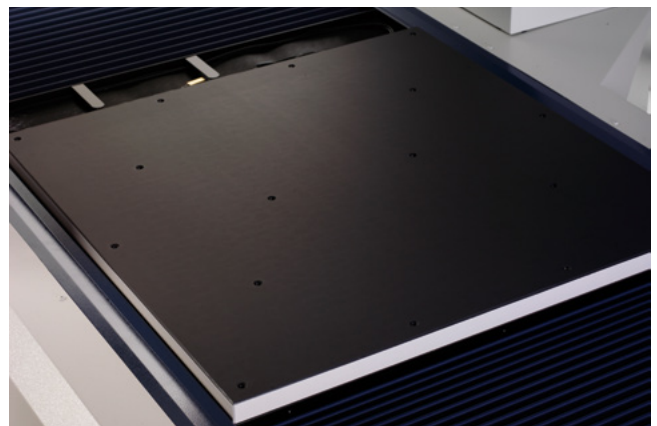

Ceramic-coated worktable

# Evolving technology

## Thorough analysis and elimination of error factors Part 2

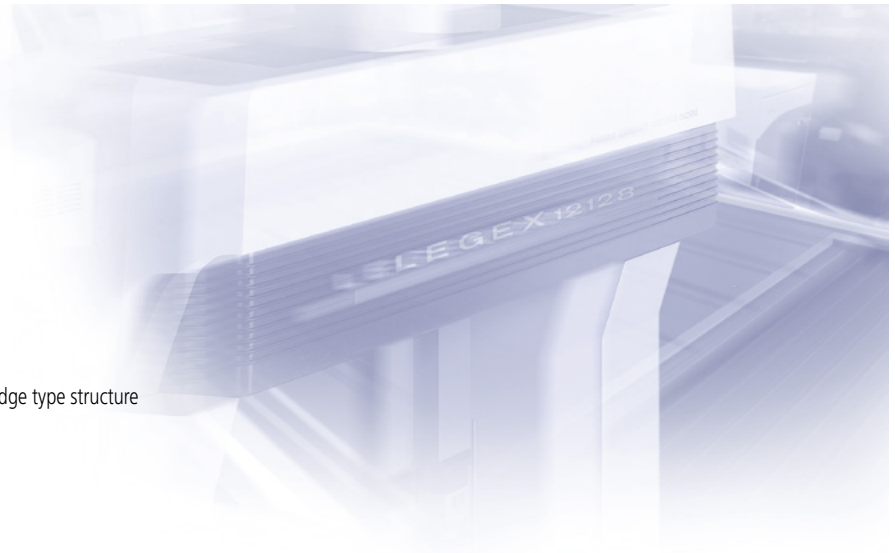
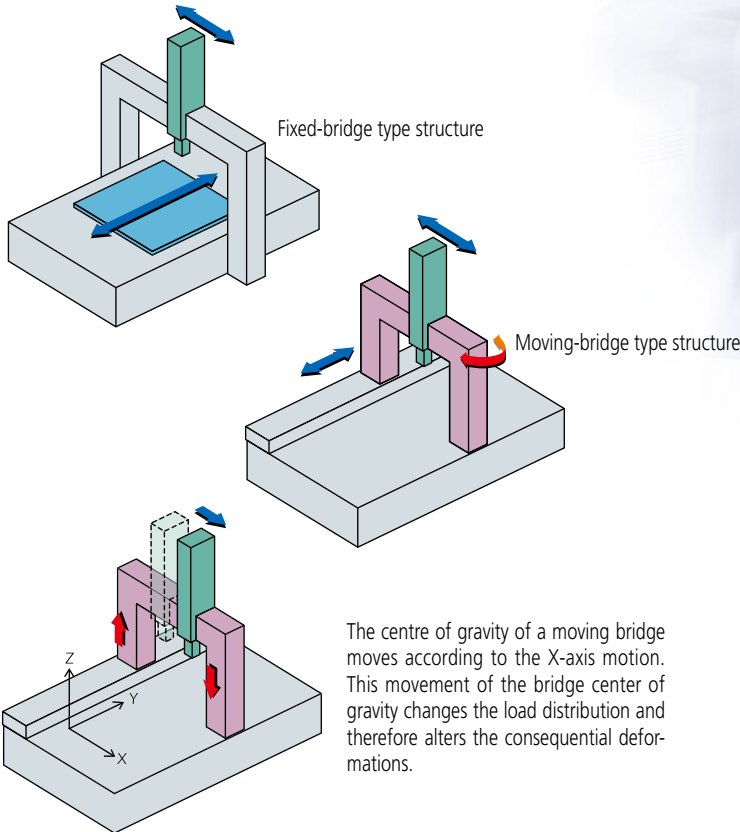

### CONSTRUCTION

#### Pitch and yaw errors practically eliminated

The LEGEX uses a fixed-bridge type structure. This is the ideal CMM architecture and virtually eliminates pitch and yaw errors. Most other CMMs use a moving-bridge design with a single drive unit under the column, which tends to cause yawing and pitching during slide movements.

### DYNAMIC ACCURACY

#### X- and Y-axis independence and a 'center of gravity' type drive system

The fixed-bridge design of the LEGEX allows the axes to operate totally independently. Movement of the X-axis slide does not change the loading on the Y-axis slide, and so does not cause deformation. Also, the 'center of gravity' type drive system places the drive units near the center of gravity of each slide. This feature allows very high speed, highly accurate measurements by reducing inertia-induced deflections during acceleration and deceleration.

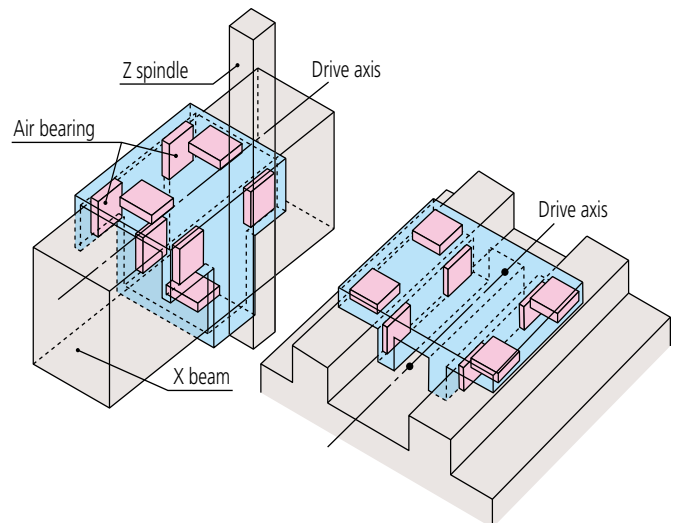

## VIBRATION CONTROL

### Isolating floor vibration

The LEGEX is hardened against floor induced vibration by use of 'air-damped spring isolators' with an auto-leveling function. This virtually eliminates factory floor vibrations from the entire machine structure.

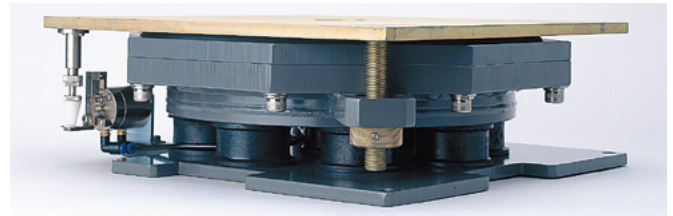

Air-damped spring isolators



Installation positions

### Floating mechanism reduces internal vibration

To reduce the effects of internally generated vibration, the LEGEX uses a special floating mechanism to couple each ballscrew to its guide block. This isolates the slide from the servo motor as it turns the ballscrew and thus prevents transmission of motor vibrations, especially during acceleration and deceleration.

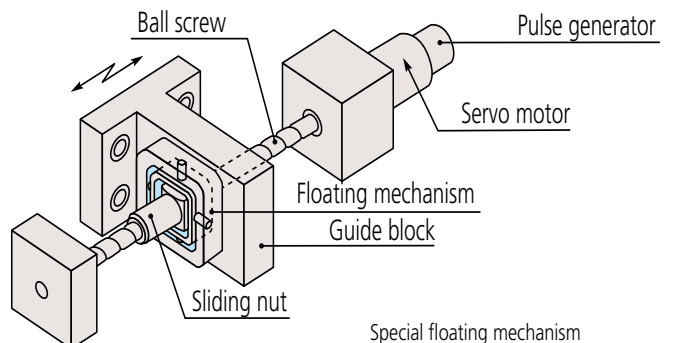
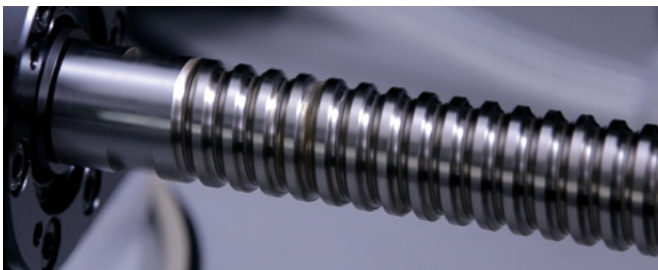

Special floating mechanism



# Evolving technology

## Thorough analysis and elimination of error factors Part 3

### LENGTH STANDARD

#### Linear glass scales with virtually zero thermal expansion coefficient

The LEGEX is equipped with crystallized-glass scales with a resolution of 0.01 $\mu$ m and an ultra-low linear expansion coefficient of 0.01 x 10<sup>-6</sup>/K. This virtually zero thermal expansion coefficient means the LEGEX can maintain its extreme accuracy in spite of thermal changes.

The scales are also mounted in a unique new way that reduces the hysteresis error to 1/5 that of previous models. The graphs below show the reduction in hysteresis error that results from this new mounting method.

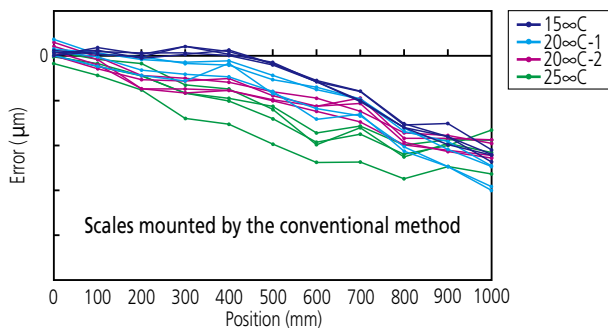
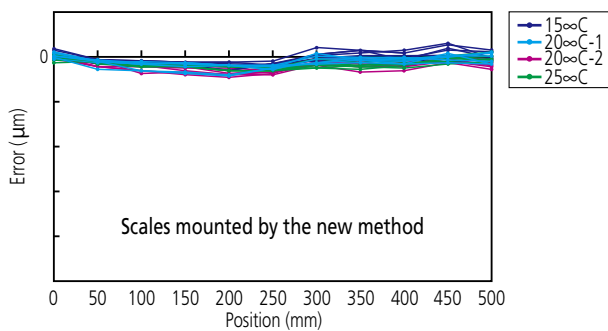
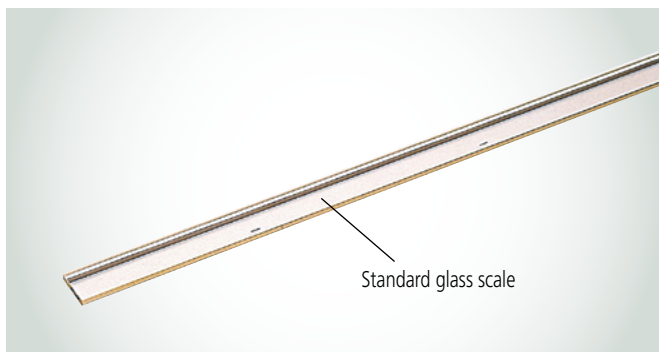

Hysteresis comparison between the conventional and the new scale mounting methods

### TEMPERATURE COMPENSATION

#### Effective over the 18°C to 22°C (64.4°F to 71.6°F) temperature range

While conventional very high accuracy CMMs require fairly strict temperature controlled environments, the LEGEX has been designed to improve the thermal stability of each component to minimize deformation. In addition, temperature sensors on each axis and for the workpiece itself detect temperature changes in real time and are used to compensate back to size at 20°C.

### STATE-OF-THE-ART CONTROL

Our proprietary control unit has been upgraded with sophisticated control technology that uses a new algorithm. A newly developed high-resolution linear encoder is also used to achieve higher accuracy.

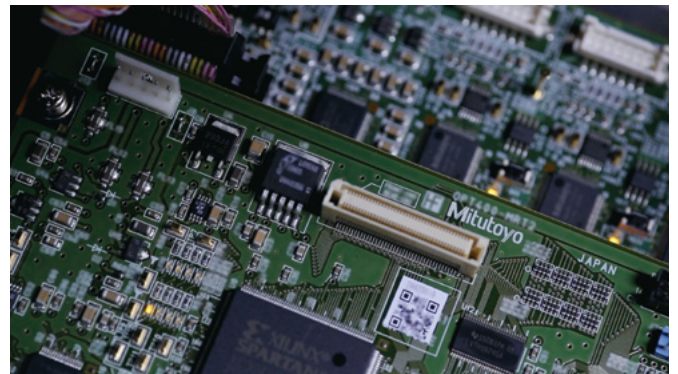



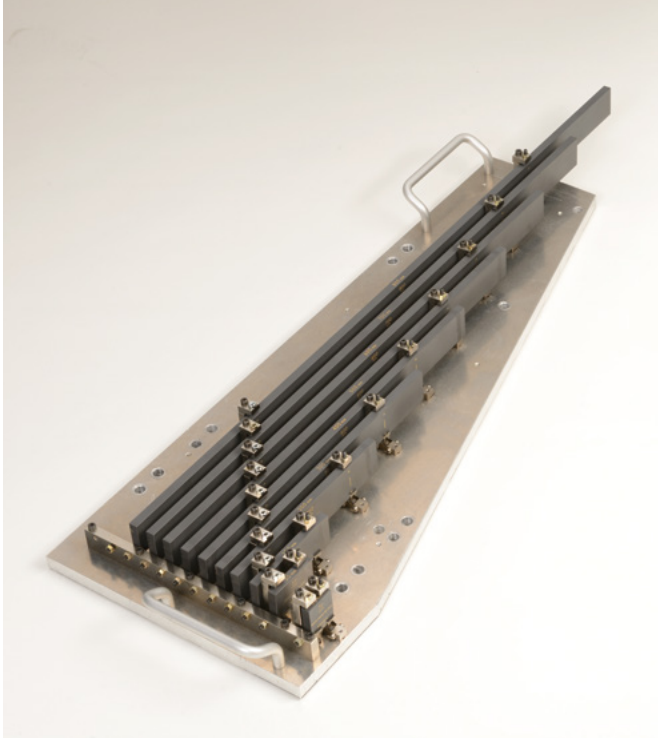

## ZERO CERA BLOCK (LOW EXPANSION CERAMIC GAUGE BLOCK)

(An optional accuracy checking accessory)

Mitutoyo offers a special check standard that matches the characteristics of the LEGEX scales. This optional accessory uses ultra-low-expansion ceramic gauge blocks with a thermal expansion coefficient in the temperature range  $20\pm 1^\circ\text{C}$  less than 1/500 that of steel ( $0\pm 0.02\times 10^{-6}/\text{K}(20^\circ\text{C})$ ). Using this ZERO CERA BLOCK standard provides a customer with the means to check the measuring accuracy of their LEGEX at any time, and so gain insight into how often their machine should be calibrated and adjusted by Mitutoyo. All gauge blocks in the standard are measured by interferometer to 0.00001mm resolution in Mitutoyo's Accredited Calibration Laboratory (JCSS No. 0030).

## TEMPERATURE STABILIZED

(An optional accuracy enhancing accessory)

Generally speaking, temperature compensation and thermally insensitive materials can widen the usable range of ambient temperature and gradients. To eliminate a common source of temperature variation, the LEGEX incorporates a special air-server. In addition to the standard air cleaning and drying functions, this air server stabilizes the temperature of air drawn from the factory air supply to  $20^\circ\text{C}\pm 0.1^\circ\text{C}$ . In combination with the machine-enclosure design and thermally insensitive glass scales, temperature-stabilized air supplied to the air bearings can produce the exceptional thermal isolation needed for low measuring uncertainties. This air supply is also used for the MPP-300 probe to provide stabilized scanning.



# Program

Mitutoyo

Controlled

Open

System

for

Modular

Operation

Support

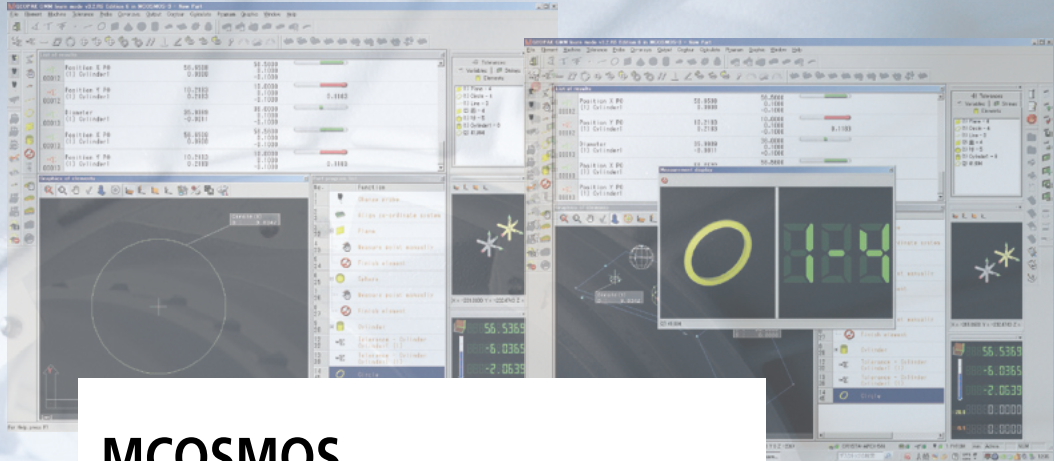

## MCOSMOS

– Mitutoyo **C**ontrolled **O**pen **S**ystem for  
**M**odular **O**peration **S**upport –

A wide variety of software modules for each manufacturing step, from design to production and to inspection, are available. In addition to a quality assurance module, they also include modules that support various types of CAD data processing, in-line measurement, data feedback, and process management.



# System performance from every viewpoint

## Performance features of standard software modules

MCOSMOS has three module configurations, from the basic MCOSMOS 1 to the advanced MCOSMOS 3. This enables a choice of appropriate functionality for your current measurement applications now with the ability to expand, if needed, in the future.

### Module configurations

	MCOSMOS 1	MCOSMOS 2	MCOSMOS 3	
	Manual			
	CNC			
<b>PART MANAGER</b> The control center from which the software package is initialized, and individual part programs are managed.		●	●	●
<b>GEOPAK</b> For (online/offline) part program creation, using the measurement of geometric elements. Extensive tolerance comparisons and output functions are included.		●	●	●
<b>CAT1000P</b> For (online/offline) part program creation, using the measurement of geometric elements directly from the CAD model, with automatic collision avoidance.			●	●
<b>CAT1000S</b> CAD model-based generation of surface measurement points, and comparison of actual/nominal data, with graphical output.			●	●
<b>SCANPAK</b> For the scanning and evaluation of workpiece contours, and 3D digitizing of surfaces.				●

## Other optional software modules

A wide variety of optional software packages that meet customer needs is available, including MAFIS Express for evaluating the shape of an airfoil, GEARPAK for evaluating gear measurements, FORMPAK-CMM, ROUNDPAK-CMM, and the MeasurLink statistical processing program.



# Probes and accessories



## MPP-310Q (Ultra High-Accuracy Scanning)

The MPP-310Q is a multi-functional probe designed for CNC coordinate measuring machines. It can not only perform a continuous path contact-type scanning measurement [a measurement method that implements a collection of a large amount of coordinate data while traveling along a continuous path in contact with the workpiece] at  $V2 \leq 0.3 \mu\text{m}^*$ , but also high-accuracy point measurement of  $\leq 0.1 \mu\text{m}$ , and data collection from a centering point measurement.

\* V2 (VDI2617) filtering is used with a standard stylus: 20°C, reference displacement: 0.25mm, measurement speed: 3mm/sec, using a  $\phi 45$  ring gage

### Omni-directional scanning

The MPP-310Q has internal high-accuracy scales with a resolution of  $0.01 \mu\text{m}$  in each direction (X, Y, and Z axes), which makes it possible to read the stylus displacement in any direction.

The air bearing employed in the sliding section of each axis helps provide this probe with minimum directionality.

### Low measuring force

MPP-310Q can reduce its measuring force to a minimum of 0.03N so that it can even measure elastic workpieces such as resins, etc., without damaging them at all.

### Fast scanning

MPP-310Q can perform fast scanning at 120mm/s. For example, it completes a measurement in just a few seconds even if it is required to measure an inside diameter of 100 mm using 1000 measurement points. In addition, measurement can be pursued effectively while changing the scanning speed, depending on the measurement accuracy required.

### Specifications

Measurement range	$\pm 1\text{mm}$
Resolution	$0.01 \mu\text{m}$
Spring rate	$0.2\text{N/mm}$

High speed scanning measurement



Point measurement

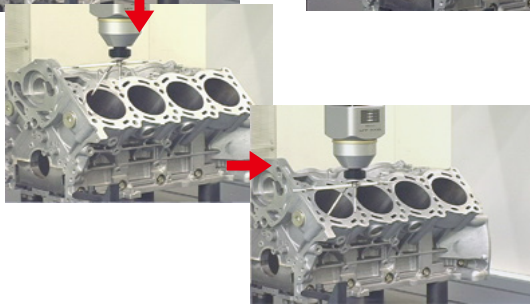

# Probes

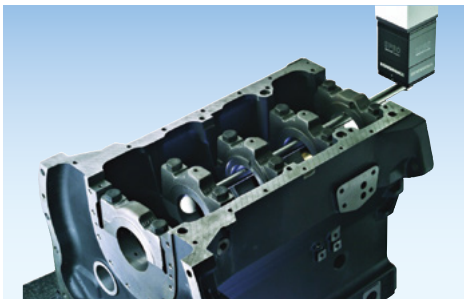

SP80 Scanning Probe  
120m/s scanning speed and 500mm long stylus

SP80 Scanning Probe Requires Special Quotation.

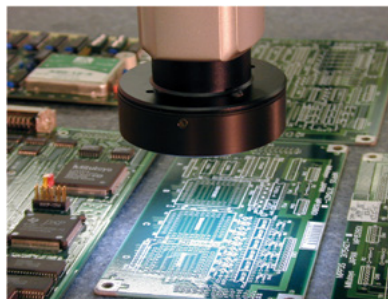

QVP

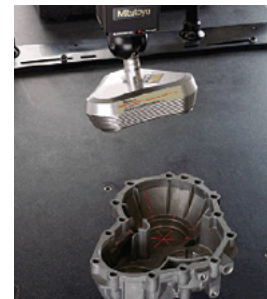

SurfaceMeasure606T

## MRT320 Rotary table

The LEGEX can be used with the MRT320 rotary table as the 4th axis. It is very efficient for gear, cylinder cam and impeller measurements.



## Specifications

Resolution		1/10000 degree (0.36 seconds)
Accuracy	Indexing accuracy	2"
	Deflection of rotation center	1mm
	Deflection of table	2mm
Maximum table load	Horizontal orientation	100kg
	Vertical orientation	50kg
Table	Diameter	ø320mm
	Height	200mm

# Technical Data

## Dimensions

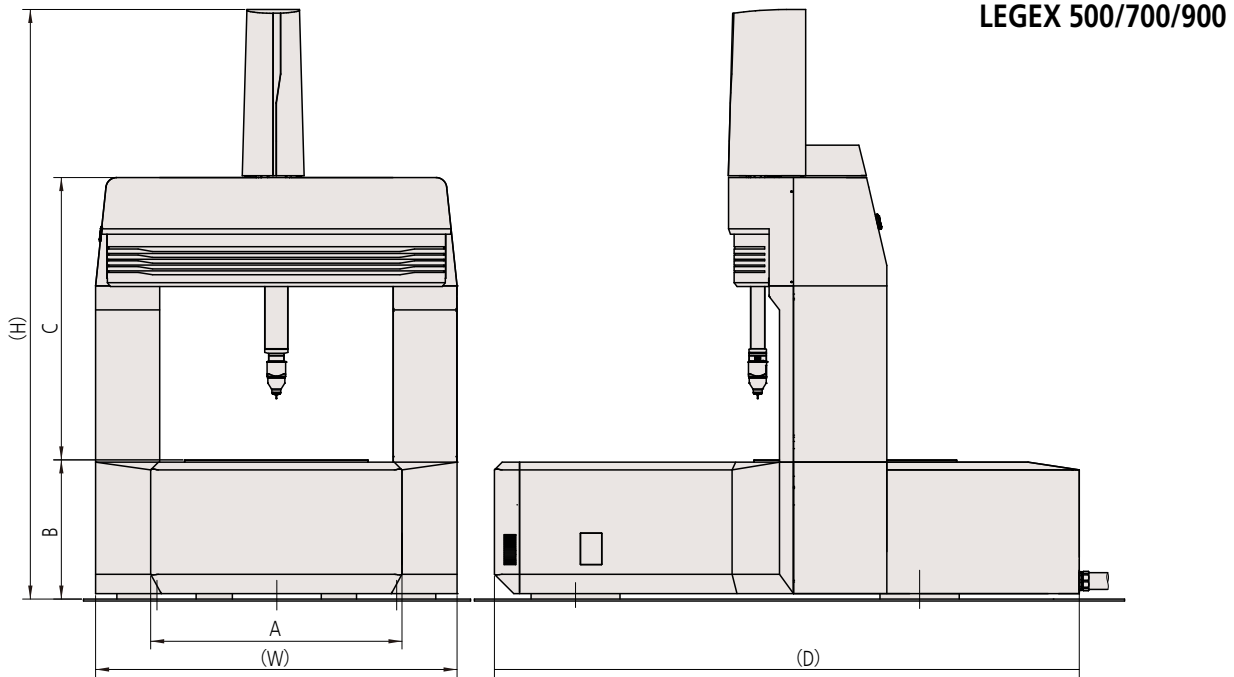

Model	Height (H)	Width (W)	Depth (D)	A	B	C
LEGEX 574	103.6"	57.9"	94.5"	35.5"	23.7"	51.7"
LEGEX 774	103.6"	65.8"	119.3"	43.3"	23.7"	57.6"
LEGEX 776	120.1"	65.8"	94.5"	51.2"	23.7"	51.7"
LEGEX 9106	115.4"	73.7"	94.5"	43.3"	28.4"	57.6"

## Floor layout (reference)

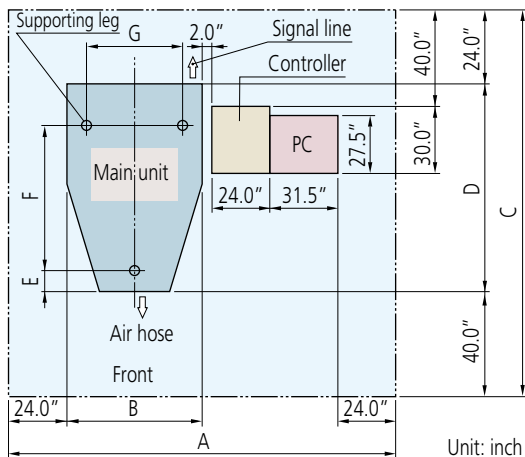

Model	A	B	C	D	E	F	G
LEGEX 574	168.0"	62.5"	164.0"	100.0"	14.5"	54.75"	35.0"
LEGEX 774	180.0"	74.5"	189.0"	125.0"	15.0"	55.5"	43.25"
LEGEX 776	185.5"	80.0"	166.0"	102.0"	15.0"	55.5"	43.25"
LEGEX 9106	180.0"	74.5"	166.0"	102.0"	16.5"	70.625"	52.625"



# SPECIFICATIONS

Items		Model	LEGEX 574	LEGEX 774	LEGEX 776	LEGEX 9106
Measuring range	X axis		19.68" (500mm)	27.55" (700mm)		35.43" (900mm)
	Y axis		27.55" (700mm)			39.36" (1000mm)
	Z axis		17.71" (450mm)	23.62" (600mm)		
Measurement method			Ultrahigh-precision linear encoder			
Maximum speed			7.8"/s (200mm/s)			
Maximum acceleration			0.1G (980mm/s <sup>2</sup> )			
Resolution			0.00000039" (0.00001mm)			
Guide method			Air bearing			
Measuring table	Material		Cast iron w/Ceramic coating			
	Size		21.65" x 29.52" (550x750mm)	29.52" x 29.52" (750x750mm)	37.40" x 41.33" (950x1050mm)	
	Tapped insert		M8x1.25mm (for workpiece clamping)			
Table loading	Maximum workpiece height		27.59" (701mm)		33.85" (860mm)	
	Maximum table loading		551 lbs. (250kg)	1,102 lbs. (500kg)		1,763 lbs. (800kg)
Mass (main unit)			7,716 lbs. (3500kg)	11,023 lbs. (5000kg)	11,243 lbs. (5100kg)	14,330 lbs. (6500kg)
Air supply	Pressure		72.5 PSI (0.5MPa)			
	Consumption		4.23 CFM (120L/min under normal conditions) air source: 5.65 CFM (160L/min or more)			

## Main unit accuracy

Unit:  $\mu\text{m}$

Probe	Length measurement error ISO 10360-2:2009 (JIS B 7440-2:2013)
MPP310Q	$E_{0,MPE} = (0.28 + L/1000)\mu\text{m}$ (Temperature environment 1) $E_{0,MPE} = (0.3 + L/1000)\mu\text{m}$ (Temperature environment 2)

\* L = measured length (mm)

\* Table at right defines temperature environments 1 and 2

## Installation temperature environment

	Temperature environment 1	Temperature environment 2
Temperature range	19 - 21°C (66.2 - 69.8°F)	18 - 22°C (64.4 - 71.6°F)
Rate of change	0.5°C (0.9°F)	
Gradient	1.0°C (1.8°F)	

# Introduction to LEGEX12128



## Main Specifications

Items		Model	LEGEX12128
Measuring range	X axis		47.24" (1200mm)
	Y axis		31.49" (800mm)
	Z axis		47.24" (1200mm)
Resolution			0.00000039" (0.00001mm)
Guide method			Air bearing
Length measurement error (Probe MPP310Q) $E_{0,MPE}$			$(0.6 + 1.5L/1000)\mu\text{m}$
Table capacity	Maximum workpiece height		41.57" (1056 mm)
	Maximum table loading		2,204 lbs. (1000kg)
Mass (main unit)			23,148 lbs. (10500kg)

\* L = measured length (mm)

\* This is a custom-order product.

\* Measurement error guaranteed at 18 - 22°C (64.4 - 71.6°F)



Note: This machine incorporates a main unit Startup system (relocation detection system), which disables operation when an unexpected vibration is applied or the machine is relocated. Be sure to contact your nearest Mitutoyo Sales Office prior to relocating this machine after initial installation.

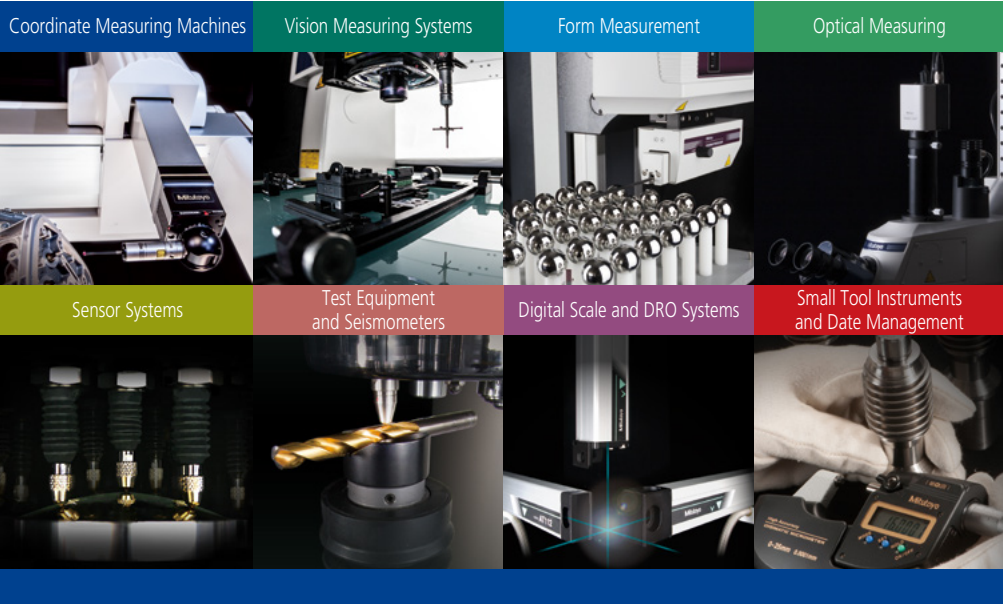

**Whatever your challenges are, Mitutoyo supports you from start to finish.**

Mitutoyo is not only a manufacturer of top quality measuring products but one that also offers qualified support for the lifetime of the equipment, backed up by comprehensive services that ensure your staff can make the very best use of the investment.

Apart from the basics of calibration and repair, Mitutoyo offers product and metrology training, as well as IT support for the sophisticated software used in modern measuring technology. We can also design, build, test and deliver measuring solutions and even, if deemed cost-effective, take your critical measurement challenges in-house on a sub-contract basis.



**Find additional product literature and our product catalog**

[www.mitutoyo.com](http://www.mitutoyo.com)

**Note:** All information regarding our products, and in particular the illustrations, drawings, dimensional and performance data contained in this printed matter as well as other technical data are to be regarded as approximate average values. We therefore reserve the right to make changes to the corresponding designs. The stated standards, similar technical regulations, descriptions and illustrations of the products were valid at the time of printing. In addition, the latest applicable version of our General Trading Conditions will apply. Only quotations submitted by ourselves may be regarded as definitive. Specifications are subject to change without notice.

Mitutoyo products are subject to US Export Administration Regulations (EAR). Re-export or relocation of our products may require prior approval by an appropriate governing authority.

**Trademarks and Registrations**

Designations used by companies to distinguish their products are often claimed as trademarks. In all instances where Mitutoyo America Corporation is aware of a claim, the product names appear in initial capital or all capital letters. The appropriate companies should be contacted for more complete trademark and registration information.



**Mitutoyo America Corporation**  
[www.mitutoyo.com](http://www.mitutoyo.com)  
 One Number to Serve You Better  
 1-888-MITUTOYO (1-888-648-8869)

- M<sup>3</sup> Solution Centers:**
- Aurora, Illinois (Headquarters)
  - Boston, Massachusetts
  - Huntersville, North Carolina
  - Mason, Ohio
  - Plymouth, Michigan
  - City of Industry, California
  - Birmingham, Alabama
  - Renton, Washington
  - Houston, Texas